

# Treatment of Flood-Damaged Older and Historic Buildings

In recent years, many older and historic buildings have been affected by the heavy rains and flooding that occurred during hurricanes and tropical storms. The purpose of this booklet is to help building owners minimize structural and cosmetic flood damage. It contains general advice written to cover a wide variety of buildings with varying degrees of flood damage. If you suspect that your building may have some structural damage, contact a qualified structural engineer or architect to thoroughly assess the situation and suggest remedies. Your state historic preservation office (SHPO) can provide you with a list of architects who are experienced in the treatment of historic buildings.

A description of the tax credit programs for rehabilitation of historic structures, free technical publications available through your state historic preservation office and the Federal Emergency Management Agency (FEMA), telephone numbers you can call for more assistance, and additional resources are provided at the end of the booklet.

Once you are able to return to your building, the first tasks will likely be to remove mud and debris and to inspect the building for damage. Saving your building, no matter how historic, is not worth losing your life or risking permanent injury. Please observe these safety precautions:

- Do not walk through flowing water.
- Do not drive through a flooded area.



- Stay away from power lines and electrical wires.
- Make sure that all of your electricity is turned off. If any electrical wiring was submerged, have it inspected before turning the power back on.
- Look before you step. Floods deposit mud which makes most walking surfaces very slippery.
- Be alert for gas leaks.
- Carbon monoxide exhaust kills. If you use electrical generators or charcoal grills, make sure that they are properly vented.
- Clean everything that got wet. Floodwaters carry sewage and chemicals. Hose down concrete and masonry walls. Scrub all surfaces with disinfectant. Discard any food and medicine that came in contact with floodwater. Wear protective clothing and make sure the building is properly ventilated while working inside.
- Remember to follow local health guidelines concerning preventive shots or vaccinations.

## **After the Water Recedes**

No other “element” is as destructive to buildings as water. After your building has been saturated and once the floodwaters recede, it is important that the drying process begin immediately. Most of the damaging effects of water, such as rot, rust, and spalling, can be minimized by reducing both interior and exterior moisture levels.

The least damaging drying process appears to be one that begins by using only ventilation. To speed evaporation, interior air must be vented to the outside. The most effective way to do this is to open windows and doors and allow the moisture to escape. Fans can be used to speed evaporation by moving interior air and exhausting humid air to the outdoors.

*In 2005, floodwaters severely damaged New Orleans and other communities along the Gulf Coast following Hurricanes Katrina and Rita.*



**NATIONAL TRUST**  
for HISTORIC PRESERVATION®

1785 Massachusetts Avenue, N.W.  
Washington, DC 20036  
202.588.6296



*Bonaparte, Iowa, has rebounded from a 1993 flood that deposited water and mud throughout three blocks of the town and damaged every building in the town's historic riverfront district.*

Using heat or dehumidification too soon can damage your building. As materials begin to dry, small amounts of heat or dehumidification can be introduced. In particularly hot and humid areas, however, such as the Gulf Coast, experts recommend closing up the building and using dehumidifiers and air conditioners to complete the drying once the ventilation ceases to help. Use of mechanical means requires some caution:

- None of these devices should be used when water makes their operation dangerous.

- Ventilation remains the primary means of removing interior moisture. All of these devices must be used in conjunction with a ventilation plan designed to exhaust moisture-laden air.
- Beware of using industrial drying equipment to remove moisture at a very fast rate. You are likely to cause permanent damage to wood and plaster.
- If heaters are used without ventilation, the relative humidity in the interior may actually increase and further spread moisture damage. If heaters are fuel powered, the lack of ventilation can be very dangerous to persons inside the building. Enclosed portions of your building, such as wall cavities, may retain water for long periods of time which can pose a danger particularly to wooden elements such as wall studs, floor joists, and columns. It may be necessary to open walls and remove insulation. Later sections of this booklet contain specific recommendations.

Once the floodwaters recede, you will need to rinse remaining mud, dirt, and flood debris from all surfaces with fresh water as soon as possible. It is safer and easier to remove the mud while it is still wet. Do not wait until the material is dry. Make sure that all electricity is turned off before cleaning with water. Avoid using high pressure water on historic materials and exercise extreme care when washing decorative features and damaged or loosened elements.

Silt and mud will accumulate not only on the floor and furnishings, but in interior wall cavities as well. Be sure to open electrical outlets and mechanical chases and rinse these areas thor-

oughly. Check wiring and connections for damage and repair as required. Let areas dry before closing them. Check heating and air conditioning ducts and clean out any mud or dirt before turning on the units. Large systems may need to be dismantled or cleaned by a professional.

To clean any remaining dirt and stains, use a standard non-sudsing household cleaning product as directed by the manufacturer. Special care should be used when working on or around historic materials. After cleaning, use a disinfectant to kill the germs, bacteria, and odor left by floodwaters.

Keep in mind that floodwaters and the remaining silt are contaminated by sewage and chemicals. Protect your eyes, mouth, and hands, and wear a mask and rubber gloves when cleaning out debris left by floodwaters. Use disinfectants to wash your hands before eating.

Before you begin to clean up your historic property, it is important to carefully document any damage to the structure. This is essential not only for insurance purposes, but also to record important historic building features. If building components are removed for cleaning or repair purposes, a photograph will help to ensure that they are reinstalled correctly.

Take photographs and make written notes describing the damage. A video recording is also a very effective way to document flood damage. Take photos or videos of any discarded items. Because of the intensive cleanup that takes place following a flood, materials might be carted away before an insurance adjuster is able to assess the loss.

Create an inventory of found items, dislodged architectural features, decorative fragments, and furnishings. **Do not throw away materials at will.** Furnishings and architectural elements can be carried a great distance by floodwaters, and items found on your property may be extremely valuable to a nearby restoration project.

## Hydrostatic Pressure

If your basement is flooded, it is likely that the level of water in your basement is the same as the groundwater level outside of your house. When this happens, pumping the water from the basement will do no good. New water will continue to seep in until the groundwater level drops.

### **Foundation Collapse**

You should be aware that pumping water from your basement can be dangerous. This water may be providing the necessary pressure to balance the hydrostatic pressure of the groundwater. If the groundwater level is higher than your basement floor and you pump the water from your basement, the foundation walls could be pushed inward and collapse.

If your basement is flooded with several feet of water and you are reasonably certain that your floor drains are operational, you can assume that the groundwater table is high. It is advisable to leave the water in place until the groundwater table sinks and the water recedes by itself. If your basement contains only a few inches of water, however, you may be able to pump it out safely. Keep in mind that if the groundwater level is higher than the floor, the water will return.

Even if you cannot pump the water out of the basement, you should still begin to ventilate the

rest of the building. The sooner these materials dry, the less chance of water-related problems. Consult with local health officials to determine if there is any sanitizing agent that can be used to treat standing water in the basement.

Water can exert tremendous pressure on foundation walls and floor slabs. If any portion of a building lies below the groundwater level, one of two things will happen: basement slab heaving or loss of mortar.

### **Basement Slab Heaving**

If foundation walls are tight enough to hold back groundwater, it is likely to seep through the floor slab, causing it to leak or heave. In some instances, very high water pressure may be enough to raise the floor slab. Fortunately, this is not a common occurrence in historic buildings.

If your basement slab heaves, you cannot correct the problem immediately. First wait until the soil beneath the building dries thoroughly, as part of the problem may be the presence of clay soils that expand when wet. Concrete slabs in newer buildings are usually poured over a sand bed, which helps them to resist soil pressures, while older concrete floors were often poured right over the existing dirt. If you pour a new slab or surface-coat the existing slab before the clay dries, the new slab or surface could crack when the clay shrinks to its normal dimensions.

If the slab is still heaved or cracks remain after the water recedes and the soil has dried, there is little you can do except to repair the cracks or, in the case of severe heaving, pour a new slab.

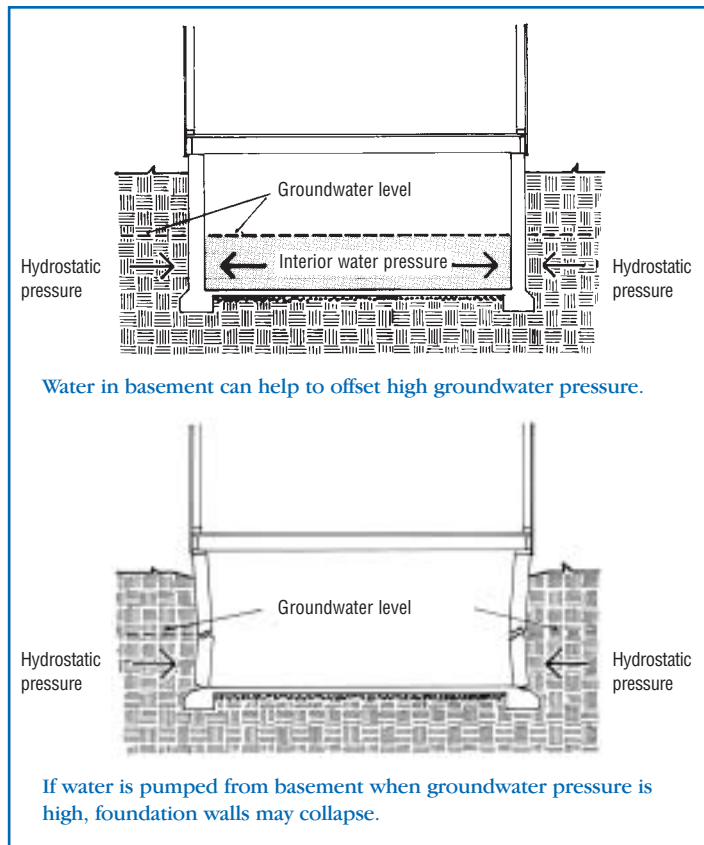
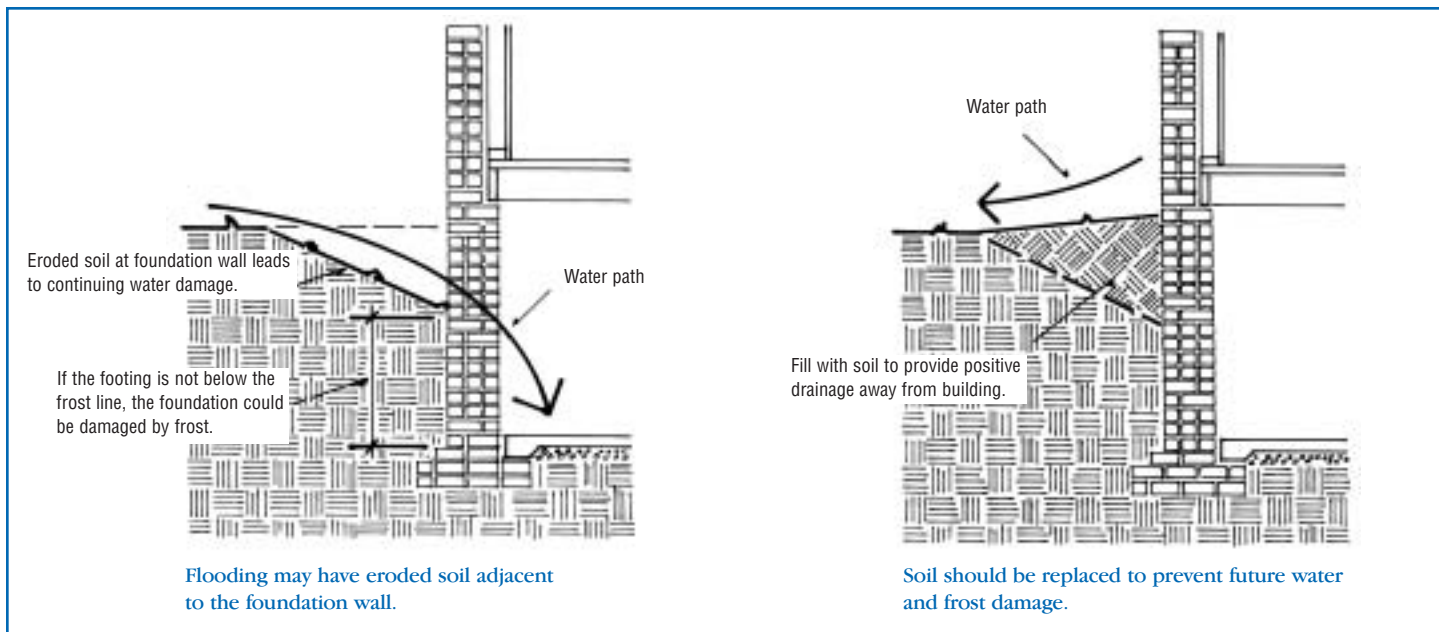

**Figure 1** Hydrostatic Pressure

### **Loss of Mortar**

The basement may leak and fill with water. This is usually the case with older buildings and actually protects the foundation walls from collapse if the groundwater level is too high. Unfortunately, as water passes through stone and brick foundation walls, it sometimes carries mortar with it.

The foundations of most older and historic buildings are masonry. Stone foundation walls with soft lime mortar are very durable, although the lime mortar does not hold up well to water erosion. Inspect the mortar of stone masonry foundation walls to ensure that it has not leached from the joints and made the wall unstable. If a significant amount of mortar has been lost, it can usually be replaced without dismantling the wall. In many cases, a “loose” mortar can be poured into the joints to fill the voids.



**Figure 2 Foundation Erosion**

Make sure that replacement mortar is not too hard for the surrounding stone. If the wall is constructed of sandstone, the new mortar should contain at least two parts hydrated lime to each part of white Portland cement and nine parts sand (known as ASTM “Type O” mortar). If the foundation wall is constructed of limestone or other relatively hard stone, a standard tuckpointing mortar may be used (ASTM “Type N” containing one part hydrated lime to one part white Portland cement and six parts sand).

If the foundation walls are constructed of brick masonry or concrete block, there will likely be less leeching of mortar than if the walls were constructed of stone. Nevertheless, they should be inspected for missing mortar and repaired in the same manner as aboveground walls, unless there is reason to suspect a more serious structural problem created by the flooding (see “Foundation Erosion” below). Generally foundations constructed of concrete block used a harder mortar containing gray Portland cement.

## Erosion

### **Foundation Erosion**

Water currents and water traveling in underground “streams” can erode soil beneath foundation walls and footings. Although this situation is not common, when it does occur the building’s foundation will be destabilized and repairs will be necessary. The best evidence of structural destabilization is the appearance of cracks in the foundation walls and in plaster or drywall above the foundations.

Keep in mind, however, that not all cracks that appear after a flood are indications of long-term instability. Some may result from temporary expansion of clay soil around the foundation. When the soil returns to its natural water content, the cracks should shrink or, at the very least, not expand. Other cracks may result from moisture-related expansion of wood beams and joists tied to the foundation walls. These cracks should shrink as the wood dries.

Cracks from foundation erosion, however, can be expected to worsen over time as the building settles slowly to its new soil support. The best indicator of this type of structural problem is cracks that move. Movement, particularly widening of cracks, is a sign of structural instability warranting careful examination by a qualified structural engineer or architect.

The best way to determine whether a crack is moving is to purchase a device called a “tell-tale.” This small gauge is glued to a wall on either side of a crack. Its markings indicate the crack’s horizontal and vertical movement over time. This device can be obtained from engineering or scientific supply firms or by contacting the manufacturer directly. (Avongard Crack Monitor, 1-800-244-7241, [www.avongard.com](http://www.avongard.com)).

Another way to determine whether movement exists is to glue a glass microscope slide across the crack. If the slide breaks, movement is occurring.

Water may erode the soil adjacent to your building. This can lead to two problems:

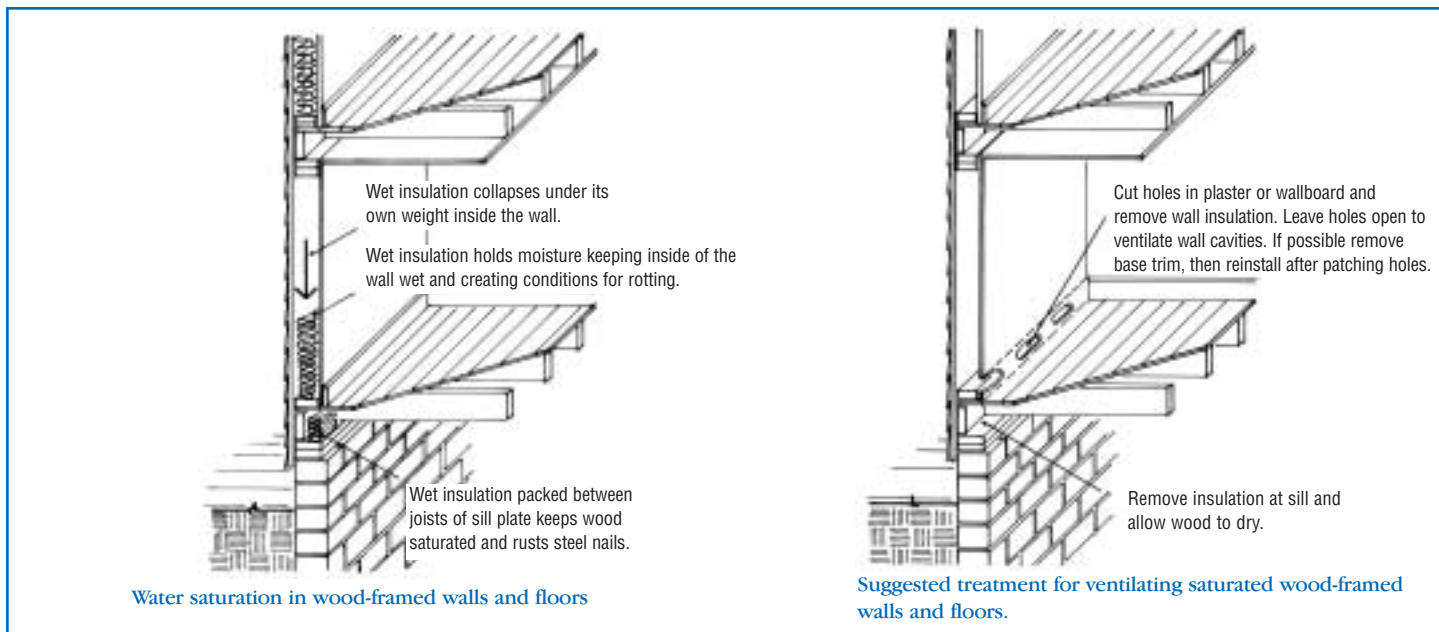

**Figure 3 Treatment for Saturated Wood-framed Walls and Floors**

The soil may be “dished” next to the building which may result in additional damage from future rain. The soil adjacent to the building should slope away from it to ensure that future rains do not drain into the building. After the floodwaters subside, check the soil drainage pattern and re-grade as necessary.

A less common soil problem is the loss of enough dirt to protect your foundation from frost-heaving during cold weather. If the foundation is not sufficiently below the frost line, it may heave upward when the ground beneath it freezes. For this reason, it is best to replace any lost dirt adjacent to the foundation.

### **Heaving of Sidewalks and Slabs**

Erosion can also affect paving. From a building conservation perspective, the worst problem occurs when eroded slabs of asphalt or concrete channel water into, rather than away from buildings. As with soil erosion, this can lead to water problems from future rains.

If this condition exists, the slab should either be raised (by mudjacking for example) or it should be removed and replaced with one that drains properly.

### **Saturation of Insulation**

With few exceptions, any insulation that has been immersed in water should be removed for two reasons:

- 1) After being saturated, most insulation is rendered permanently ineffective, particularly loose-fill varieties, such as cellulose, vermiculite, rock wool, and blown fiberglass, which tend to collapse under their own weight.
- 2) Saturated insulation holds water which, if left in place, can perpetuate high moisture conditions destructive to wood, masonry, and steel.

Some types of insulation may be left in place after water contact, such as closed-cell styrene and urethane board insulations that do not absorb water. These should be inspected to determine

whether they hold moisture against wood or masonry materials or steel fasteners. If so, the insulation should be removed until all materials are dry. Any mud or silt that remains in the cavity should be removed regardless of the insulation’s condition.

Other types of insulation, such as fiberglass battens, must be evaluated on a case-by-case basis. Glass fibers, in themselves, are not water absorbent, but if they impede the flow of air in a wall cavity, and thus the drying-out process, it may be necessary to remove them.

### **Wood Rot**

Wood rot occurs when natural fungi—present in virtually all construction lumber—grow in wood. Like other living organisms, they need food (wood), air, proper temperatures (between about 60-80 degrees F.), and water in order to grow. In most wood construction, the missing element is water which is why ordinary wood lasts for centuries when protected from moisture.

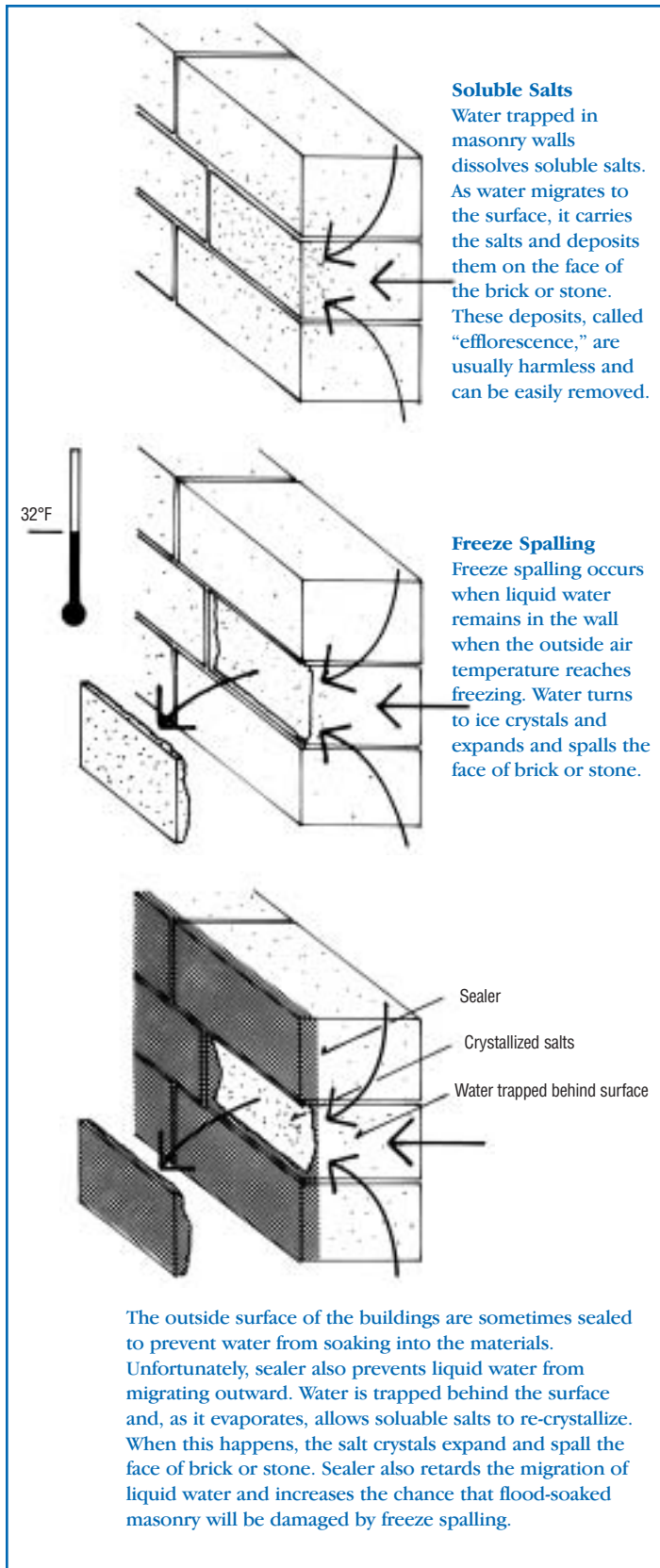

Figure 4. Masonry and Concrete Deterioration

Fortunately for flooded buildings, the fungi must exist over a relatively long period of time in order for wood rot to be destructive. Damage from a one-time event, such as a flood, is usually negligible if the wood is allowed to air dry. Problems occur when saturated wood is encapsulated so that the water cannot evaporate.

Two areas where wood is normally encapsulated are wall cavities and sill plates, particularly when these areas are filled with insulation. Figure 3 describes treatment of walls and sill plates. To properly ventilate walls, it will probably be necessary to cut or drill holes—taking care not to damage pipes and wires buried in the walls—and remove the insulation.

## Masonry and Concrete Deterioration

### Soluble Salt Damage

Masonry and concrete contain impurities, including water-soluble salts. When these materials are saturated, the soluble salts dissolve and are carried to the surface during evaporation. The result is an unsightly white residue called efflorescence on the exterior or interior of the building—wherever water evaporates. These deposits are not usually harmful and frequently they dissolve and disappear naturally when it rains. Stubborn efflorescence maybe removed with water, detergent and bristle brushes, or with chemicals.

Soluble salts can cause significant damage when the building's exterior surface has been treated with building sealer. If this is the case, the salts will travel toward the outside surface, but become trapped behind the surface by the sealer. The water vapor eventually evaporates, but the salts

are left behind to crystallize and expand, pushing off the surface of the brick or stone in a process called spalling.

The presence of paint on masonry or concrete walls may also retard the passage of water. Because the paint does not penetrate the masonry or concrete, it is usually removed by the water passing through the wall or by the salt crystallization that takes place just under the paint layer. While the paint may be removed, the surfaces of the brick, stone, or concrete remain intact.

The most obvious way to prevent salt damage is to never apply sealer to a building. If your building has been sealed, there is little that can be done to prevent spalling.

### Freezing and Thawing Damage

When water freezes, it expands. If the water is encapsulated inside building materials, the expansion can tear them apart. Thus, if significant amounts of water remain in masonry or concrete by early winter, when the weather goes through rapid periods of freezing and thawing, the result is similar to the crystallization of salts: the faces of the masonry or concrete may spall.

Ordinarily, water will evaporate even from saturated masonry and concrete at a rapid enough rate that freeze-thaw damage will not occur. Some conditions under which evaporation may be impeded and spalling may take place are described below.

- Masonry or concrete has been treated with a building sealer. Although newer building sealers allow the passage of water vapor, they inhibit the flow of liquid water and can slow the rate of evaporation. Unfortunately, lit-

tle can be done to mitigate the effects of building sealer. Some spalling may occur.

- Masonry or concrete has been painted. The vapor pressure of the water may cause some of the paint to fall off, helping to speed evaporation. Otherwise, short of paint removal, little can be done and some spalling may occur.
- Masonry or concrete has been covered with another building wood siding or plasterboard. If the covering was installed flush against the masonry or concrete, it should be removed temporarily to allow the wall to dry out. If the material was installed over sleepers or spacers and an air space exists, it may not be necessary to completely remove the covering material, but it would be helpful to provide air holes to ventilate the wall.

## Damage to Metals

### **Metal Fasteners**

Most metal fasteners are made of iron or steel which rust and expand when exposed to water. Fasteners, such as nails, should not be harmed by immersion in floodwaters, as long as they are allowed to dry soon after the waters subside. Opening wall cavities and removing insulation may be necessary. If nails are subjected to long-term moisture, rust may become severe and the nails may fail.

Rusted or weakened nails probably will not cause significant structural problems in the lower portion of a building—the portion most likely to be immersed by floodwaters. In most cases, such as at the sill plate, the nails hold the wood in position but are not solely responsible for its support.

The exception to this is often porch floor joists. Porches are frequently fastened to the house only with nails which, if they fail, may cause the porch to collapse. If your porch was submerged, make sure it is well ventilated by removing solid porch skirts and allowing the air to flow freely.

Once the moisture is removed, iron nails pose cosmetic problems by causing rust stains on finished surfaces. This problem can be corrected by driving the nails further into the wood, caulking them, and applying a primer paint with topcoat.

### **Damage to Exposed Metals**

Most metals will not be permanently damaged by immersion in water. Durable metals such as aluminum, bronze, copper, and brass should survive the flooding completely intact. Commercial storefronts with cast-iron columns and stoops may experience some rusting, but the surfaces can be sanded clean and repainted.

Stamped iron-based metal, most commonly found in “tin” ceilings and stamped metal cornices on commercial storefronts, poses more of a problem. Stamped metal consists of rust-prone iron, coated with lead and tin (called “terne”) or zinc (called “galvanized”) to prevent rust. These coatings are usually effective, unless water enters the insides of the stampings and is allowed to sit. The standing water penetrates the protective coating and the iron rusts. Stamped metal cornices that have been immersed should be inspected to make sure they haven’t filled with water. If so, find a way to drain the water and ventilate the back side, either by carefully prying a portion away from the building or by drilling small weep holes on the bottom.

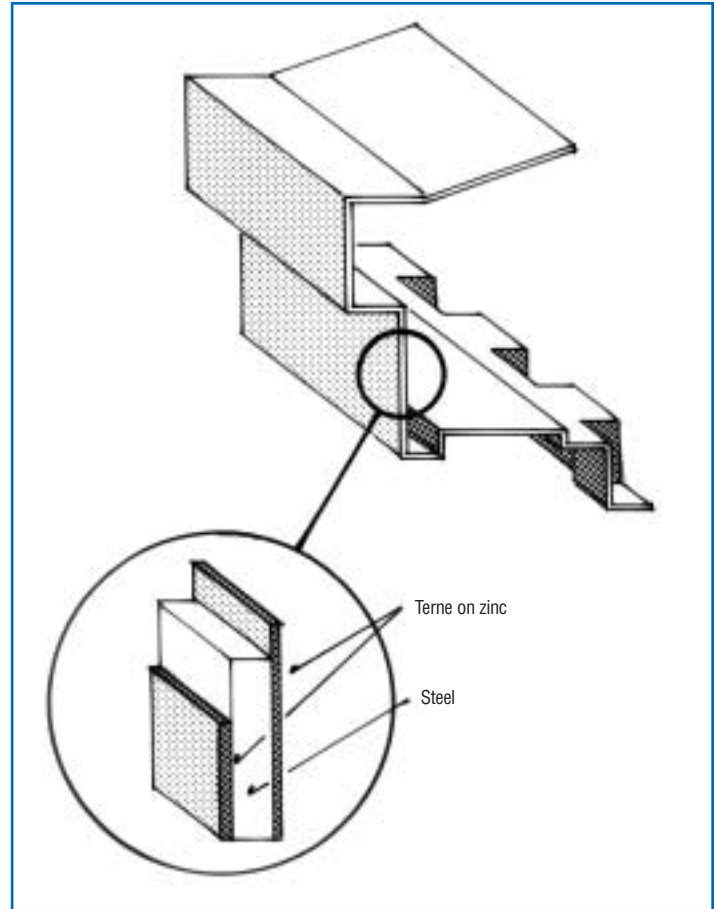
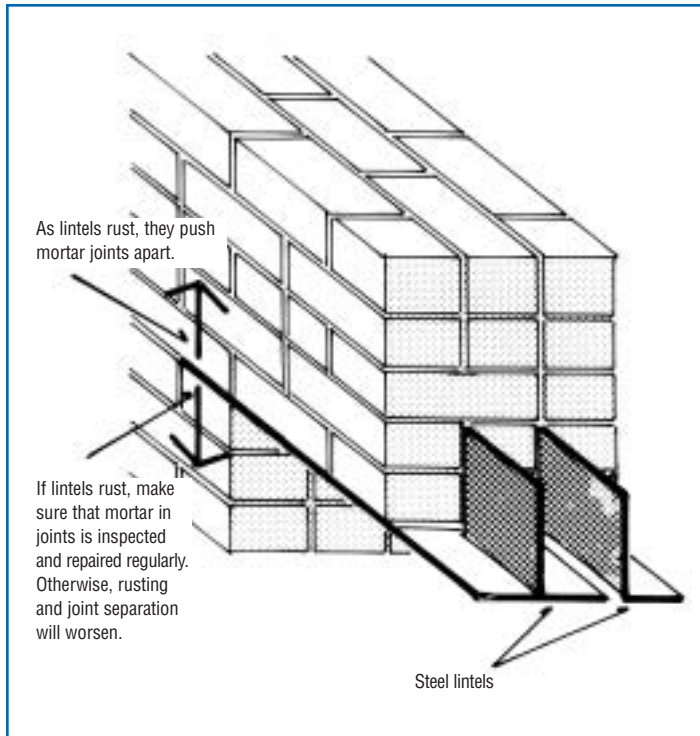

**Figure 5. Typical Coated Steel Used to Stamp Metal**

The holes can later be filled with auto body filler and repainted.

There is no easy remedy for stamped ceilings that have been immersed except to dry the building’s interior and to monitor the ceilings for possible rusting. Drilling holes to drain water may be ineffective and removing sections of the ceiling would likely result in damage to the ceiling panels.

When repairs are necessary, stamped metal should be treated like auto body work. If surface rusting occurs on stamped metal, the rust should be removed by carefully scraping only the rusted areas, priming with a rust inhibitive paint, and then painting. Do not sandblast or attempt to chemically clean stamped metal or the protective coating will be removed and the metal will rust quickly.



**Figure 6. The Effect of Floodwater on Metal Lintels in a Brick Masonry Wall**

### ***Damage to Imbedded Metals***

The problems of exposed and imbedded iron are fundamentally different. When exposed iron corrodes, the problem is mostly cosmetic. When imbedded iron corrodes, it can damage surrounding materials.

When iron rusts, it expands and this expansion generates tremendous force. Of particular concern in flooded buildings are metal lintels—the flat pieces of steel used to support masonry or concrete above door and window openings. Metal lintels are usually used on brick buildings and, when they rust, they can lift whole sections of a wall.

If your building has metal lintels and they were immersed in water, some rusting is likely to occur, although the rust expansion caused by the flooding alone will not cause a great deal of immediate damage. Of greater concern is damage to the sur-

rounding materials which may allow water to enter on an ongoing basis and cause more severe rusting in the future.

After the water recedes and the building materials dry, check the mortar joints near the lintels to see that the mortar has not cracked or fallen out. If it has, repoint the area immediately to make sure that water cannot enter to create further rusting. Before repointing, scrape the metal to remove any loose rust scale. It is uncertain whether rust inhibitive primers are effective in retarding rust in these situations.

If other iron-based metals are imbedded in masonry or concrete, inspect them periodically and repair cracks in the surrounding materials if they occur.

### **Damage to Interior Finishes**

#### ***Drywall***

Drywall that was submerged will probably have to be replaced. Drywall consists of a relatively soft gypsum material held in place by a paper “sandwich.” The paper does not hold up well to water saturation and, in most cases, wet drywall will simply dissolve. If it was not wet severely, drywall may be salvageable after it dries. Even so, FEMA recommends replacement as contaminants may make it a permanent health hazard. As with other aspects of flood cleanup, use your judgment about whether to retain or discard affected drywall.

Plaster, on the other hand, is unpredictable when wet. Sometimes it survives with no damage, other times it must be replaced. Its durability depends on the plaster mix, the skill used in application, the degree of saturation, whether it is applied to walls or ceilings, and the type of

lath used. Plaster over metal lath is more likely to require replacement than plaster over wood lath.

Check for obvious areas where plaster must be removed, such as ceilings with large sags. If your ceiling sags in an area more than about three feet in diameter, it may be difficult to repair the damage. That portion of the ceiling may need to be removed with care. Falling plaster, especially wet falling plaster, can be dangerous. If the water level was above the ceiling and you suspect that it may contain standing water, you may want to poke drain holes—with a nail attached to the end of a long stick—in the plaster before attempting to remove it. Do not stand directly under the area being prodded in case the plaster loosens and falls.

Except for areas of obvious damage, the best way to determine whether plaster must be replaced is to let it dry and then inspect it. Here are some suggestions about how to determine whether plaster should be replaced:

- The surface condition of plaster may not tell you whether it is sound. If the plaster keys (sections of plaster that serve to anchor the plaster to the lath) have fallen off or if the lath has come loose from the building structure, the plaster may need to be replaced.
- You can sometimes tell if plaster is sound by tapping lightly on the wall with a piece of wood. Unsound plaster will sound hollow.
- If you ventilate wall cavities by opening holes, look for broken plaster keys. There will always be a few broken keys, but if the number is excessive, the plaster is likely in poor condition.



- Plaster damage can be repaired by re-anchoring the plaster to the wall studs and ceiling joists with screws and plaster washers. Sound plaster, especially decorative plaster, should be retained in place if it is salvageable.

### **Damage to Wood Floors and Trim**

It is difficult to determine whether wood trim that has been submerged needs to be replaced. Most wood will expand and deform when wet and then return more or less to its original form as it dries. The behavior of an individual piece of wood depends on its species, grain pattern, method of anchoring, and whether its grain structure was damaged when the wood expanded against other materials.

Tongue and groove hardwood floors are unlikely to return to their original condition. When they expand, their grain structures are usually damaged. If you have a saturated hardwood floor, let it dry thoroughly. Then, if it remains cupped, you can decide whether to sand the floor flat or replace it. When possible, retain original hardwood floors.

Non-interlocking board floors, such as plain pine boards, stand a good chance of returning to their original shapes when dried. A light, surface sanding and some re-nailing may be necessary.

Wood trim around baseboards, ceilings, doors, and windows is likely to survive a flood because it can usually expand without crushing its fibers. After drying, it should return to its original form and should be retained.

Wooden doors in older and historic buildings are likely to be panel doors that add to the character of the building. Replacement with standard, hollow-core, flush doors may not be appropriate and the original doors should be retained

when possible. Fortunately, panel doors usually survive flooding surprisingly well. If you have panel doors, let them dry in place. It may help to open them to allow better air circulation. As they dry, warping should disappear, and their fit and the condition of their glue joints should be inspected before determining whether they need further repair. Be sure that the doors are completely dry before attempting to repair or plane them. Also, if the original glue was not waterproof, the joints may have to be re-glued.

If you need to replace any doors, consider replicating original panel doors. Hollow core doors will likely need to be replaced because their internal spacers are usually made of cardboard which dissolves in water.

### **Damage to Interior Paint**

After the flood, most painted interior surfaces that were under water will have to be repainted due to water damage or contamination. Do not paint interior surfaces until they are completely dry and the interior humidity has returned to nearly normal levels. The exception is that wall surfaces can be painted with flat latex paint even if some dampness exists.

The paint on some surfaces, such as window trim, may have been damaged and will be soft enough to scrape off. If so, new paint will not adhere until the existing paint is removed and the wood is dry. Because the wood trim may contain lead-based paint, especially in older buildings, observe caution when removing it and dispose of it properly.

### **Wallpaper**

In many cases, older and historic wallpaper may be saved after a flood, but the decision to retain or remove it is a difficult one. On the one hand, FEMA cautions

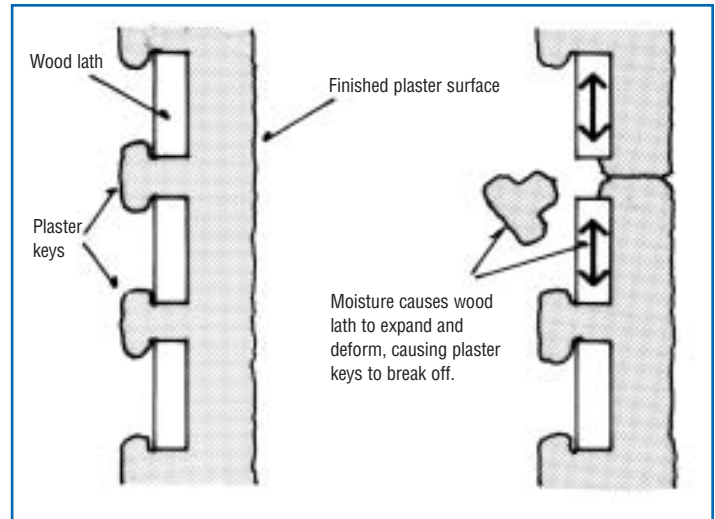

**Figure 7. Possible Effect of Saturation on Plaster Walls**

that wallpaper paste may be a breeding ground for molds and contamination and that wallpaper significantly wet by floodwaters may have to be removed and replaced, even if it appears to be in good condition. On the other hand, if the wallpaper is of historical importance or original to your house, you may decide to retain it. The decision will be based on the degree of water damage, the cost of replacement or reproduction, and climate controls that may limit future growth of mold and bacteria.

If your house is historic and the extent of damage determines that the wallpaper must be removed, carefully remove several square feet, all the way down to the plaster. If possible, take samples from several different locations including the ceiling. Label which room the paper came from and store temporarily in a dry part of the house until the paper can be permanently preserved.

### **Floor Coverings**

Most older and historic homes retain few of their original floor coverings and most floor coverings can be discarded with no effect on a building's historic character.



*Many older buildings have withstood the test of time and have survived devastating floods. With proper cleaning and drying out, they can be restored for future use.*

*— Photo by Mary Ruffin Hanbury*

One exception to this rule is tile floors which may be original. Even though tile is a durable material, the materials beneath it, such as wooden sub-floors and grout beds, may have been damaged. The only way to determine whether a tile floor is sound is to inspect it when all of the building materials are dry. This might take a long time as the tile impedes the evaporation process.

If a preliminary inspection shows that the underlying structure may be damaged, the tile floor can be removed and re-laid when the materials have dried. Or the decision whether to remove or reinstall can be postponed until the materials have thoroughly dried with the tile floor in place. The latter method takes longer, but minimizes damage to the tiles.

The most common residential floor covering is wall-to-wall carpeting. Because of the risk of contamination, carpeting touched by the flood waters should be discarded, unless it is small enough to be laundered, such as an area rug, or valuable enough to be professionally cleaned, such as an Oriental rug.

Floor tiles, such as vinyl flooring, and sheet flooring are probably not historic and should be removed to aid the evaporation process if the underlying wooden floor was submerged. On rare occasions, some sheet flooring, such as linoleum, may be historically significant. If this is the case and you wish to retain it, let the floor dry as best it can. Once dry, if the floor is level and the flooring adheres, you may leave it in place. If the bond between the floor and the covering fails, you may be able to remove and re-lay the flooring. There is no guarantee that either of these techniques will succeed. If it is impossible to re-lay the floor, make sure to save samples of the historic flooring.

### Exterior Paint Problems

Paint failure is likely to occur on any painted surface wet directly by floodwater or on surfaces through which excessive amounts of water will evaporate. Paint failure resulting from the passage of water or water vapor will show up as large sections of paint peeling all the way down to the underlying building material. If

this happens, allow the underlying materials to dry thoroughly before attempting to repaint. If you paint before all the building materials have dried thoroughly, the water vapor pressure will “bubble” the new paint and it too will peel.

If the building materials are very wet, it may be necessary to postpone painting for a long time. You may wish to use a water-repellent wood preservative to help to protect the wood from water-related damage and the effects of sunlight until you can safely paint it.

### Summary

Churches, schoolhouses, stores, banks, homes, courthouses, and barns in river and coastal communities often bear watermarks on the walls where owners pencil in the dates and levels of significant floods—the 1937 Flood, the 1973 Flood, the Johnstown Flood. Yet many of these buildings have stood the test of time and survived devastating floods. While floodwaters can cause significant damage to historic buildings, they do not spell the

end. With proper cleaning and drying out procedures, the only reminder of floodwaters in historic structures should be a watermark and date on the wall.

## Resources

The Preservation Briefs series, published by the **National Park Service**, provide useful technical information in dealing with the effects of floodwater damage to your old or historic building. Many of these are available online. For a listing of topics go to [www.cr.nps.gov/hps/tps/tpscat.htm](http://www.cr.nps.gov/hps/tps/tpscat.htm). You can also order copies from the Government Printing Office by calling 1-866-512-1800 or by sending an e-mail to [ContactCenter@gpo.gov](mailto:ContactCenter@gpo.gov).

The National Park Service Museum Management Program offers a useful primer on disaster preparedness, management and response. For more information go to [www.cr.nps.gov/museum/publications/index.htm](http://www.cr.nps.gov/museum/publications/index.htm)

**The Federal Emergency Management Agency (FEMA)** also produces several publications that may be helpful to you. These are:

- Repairing Your Flooded Home – FEMA 234
- Flood Emergency and Residential Repair Handbook – FIA 13
- Floodproofing Residential Structures – FEMA 102
- Design Manual for Retrofitting Flood-Prone Residential Structures – FEMA 114

Copies of these publications may be available through your state or local office of emergency services. Or go to [www.fema.gov/library/prepandprev.shtm#floods](http://www.fema.gov/library/prepandprev.shtm#floods). Printed copies of many of the resources listed in the FEMA

Library are available in the FEMA Publication Distribution Center. Call 800-480-2520 for ordering information.

A new resource from the **Heritage Emergency National Task Force** identifies federal funding to help plan for emergencies, buy disaster supplies, or train staff for next year's hurricane season. *Before and After Disasters: Federal Funding for Cultural Institutions* provides information on 15 federal grant and loan programs to help cultural institutions and historic sites prepare for and recover from disasters. The 32-page booklet is online. In addition, up to 50 free copies can be ordered from FEMA by calling (800) 480-2520 and asking for FEMA publication #533. [www.heritagepreservation.org/PDFS/Disaster.pdf](http://www.heritagepreservation.org/PDFS/Disaster.pdf)

FEMA has ten regional offices. Each region serves several states, and regional staff work directly with the states to help plan for disasters, develop mitigation programs, and meet needs when major disasters occur.

The location of FEMA Regional Offices and the states served are listed below.

**FEMA Region I**  
99 High Street, 6th Floor  
Boston, MA 02110  
(617) 956-7506  
(CT, MA, ME, NH, RI, VT)

**FEMA Region II**  
26 Federal Plaza  
New York, NY 10278  
(212) 680-3609  
(NJ, NY, PR, VI)

**FEMA Region III**  
615 Chestnut Street  
Philadelphia, PA 19106  
(215) 931-5608  
(DC, DE, MD, PA, VA, WV)

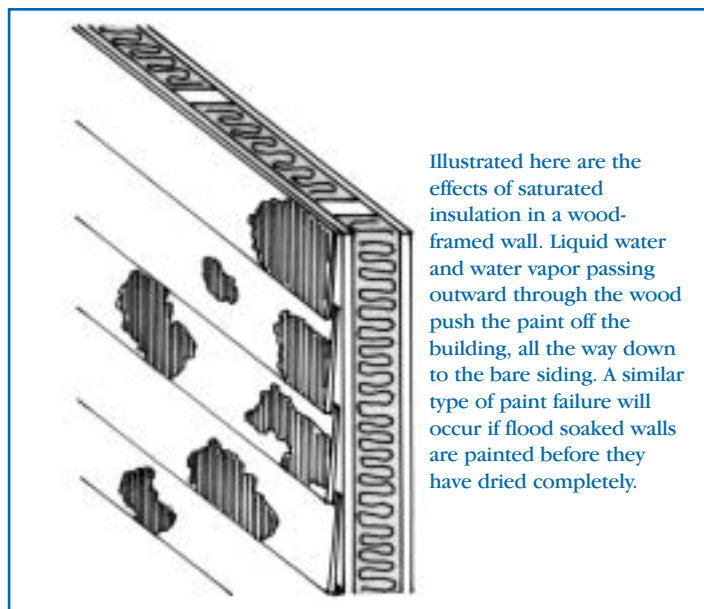

Illustrated here are the effects of saturated insulation in a wood-framed wall. Liquid water and water vapor passing outward through the wood push the paint off the building, all the way down to the bare siding. A similar type of paint failure will occur if flood soaked walls are painted before they have dried completely.

**Figure 8. Moisture-related Paint Failure**

**FEMA Region IV**  
3003 Chamblee-Tucker Rd.  
Atlanta, GA 30341  
(770) 220-5200  
(AL, FL, GA, KY, MS, NC, SC, TN)

**FEMA Region V**  
536 South Clark St.  
Chicago, IL 60605  
(312) 408-5500  
(IL, IN, MI, MN, OH, WI)

**FEMA Region VI**  
Federal Regional Center  
800 N. Loop 288  
Denton, TX 76209  
(940) 898-5399  
(AR, LA, NM, OK, TX)

**FEMA Region VII**  
9221 Ward Parkway, Suite 300  
Kansas City, MO 64114  
(816) 283-7061  
(IA, KS, MO, NE)

**FEMA Region VIII**  
Building 710, Box 25267  
Denver, CO 80225-0267  
(303) 235-4800  
(CO, MT, ND, SD, UT, WY)

## Mold Removal Guidelines for your Flooded Home

A flood-damaged home needs special care to remove mold safely and effectively. Mold begins to grow on materials that stay wet longer than two or three days. The longer it grows, the greater the health hazard and the harder it is to control. So, as soon as it is safe to return, don't delay cleanup and dry out.

Take photographs for insurance purposes before cleaning up. Do not wait for the claims adjuster to see the site before removing wet and moldy materials. Most homeowners' insurance policies do not cover mold damages or clean up costs, but flood insurance may cover it.

### **Mold and Health**

Some people are much more sensitive to mold than others, but long-term or heavy exposure is unhealthy for anyone. Mold can trigger allergic reactions and asthma attacks, may lower resistance to illness, or have other effects. Young children, the elderly, and people in poor health are most vulnerable. Some molds can make toxins that exist in live or dead spores and fragments. "Black mold" is a misleading term; many molds are black.

Mold testing is not usually needed and is rarely useful to answer health concerns. Some insurance companies and legal services may require sampling for evidence. Professional mold remediation contractors may test before and after cleanup to check the cleanup's effectiveness.

If you hire a contractor, seek a licensed mold remediation contractor with special training and equipment. Get in writing the cost, methods, and steps to be used. Compare their procedures with the following guidelines.

### **Do-it-yourself Mold Clean Up Steps**

To clean up safely and effectively, follow these steps and refer to EPA's *A Brief Guide To Mold, Moisture, and Your Home* or *Mold Remediation In Schools and Commercial Buildings* available online at [www.epa.gov/mold](http://www.epa.gov/mold) or the CDC's *Mold Prevention Strategies and Possible Health Effects in the Aftermath of Hurricanes Katrina and Rita* available online at [www.bt.cdc.gov/disasters/mold/report/](http://www.bt.cdc.gov/disasters/mold/report/).

#### **1. Wear Protective Gear During Cleanup**

People are mainly exposed to mold by breathing spores and skin contact. Wear gloves, goggles, and a respirator rated N-95 or higher. Some respirators have valves to make it easier to breathe.

#### **2. Isolate Work Area and Ventilate to Outdoors**

Disturbing mold colonies during cleanup can cause a huge release of spores into the air, so seal off the moldy areas from the rest of the house. Open windows, and don't run the central air system

during cleanup. Tape plastic over air grilles, and drape plastic in the stairwell if the second story is dry and clean. If power is on, put a fan in a window to blow out and exhaust mold-filled air to the outdoors.

#### **3. Remove Moldy Porous Materials**

Porous moldy or sewage-contaminated materials should be removed, put in plastic bags if possible, and thrown away. To reduce the release and spread of mold spores, it is helpful to cover moldy material with plastic sheeting before removing it.

- Remove all flooded carpeting, upholstery, fabrics, and mattresses right away. It's best to discard them, but if you hope to salvage a valuable item, have it cleaned, disinfected, and dried quickly outside the home. Never reuse flooded padding.
- Remove all wet fibrous insulation—even if wallboard appears to be dry. Wet insulation will stay wet far too long, leading to the growth of hidden unhealthy mold and decay fungi inside the walls. Cut wall covering above the level that was wet; water can wick up above the flood level.
- It's best to remove all moldy porous materials, especially if there is heavy or long-term mold growth—including gypsum wallboard, processed wood products, ceiling tiles, and paper products.
- Plaster, wood paneling, and non-paper faced gypsum board walls that are dry, in good condition, and have no insulation in the wall can be cleaned and sanitized to salvage them. There is a risk of mold on the back side, however, which can release spores into the home through air leaks in the walls.
- Remove vinyl wallpaper, flooring, and other coverings of wet materials.

#### **4. Clean and Disinfect**

Surface mold can be effectively cleaned from non-porous materials such as hard plastic, concrete, glass, and metal. Solid wood can also be cleaned. Cleaning should remove, not just kill, the mold, because dead spores can still cause health problems.

After cleaning, you may use a disinfectant to kill any mold missed by the cleaning. If there was sewage contamination, disinfection is a must. If you disinfect, follow label directions and warnings, handle carefully, and never mix bleach with ammonia or acids. Many disinfectants kill molds, but do not prevent regrowth.

- Remove any sediment. Hose out opened wall cavities.
- Wash dirty or moldy materials with non-phosphate all-purpose cleaners. Rough surfaces may need to be scrubbed. Rinse surfaces, but avoid pressure spray which can force water into materials.
- Disinfect wall cavities and other materials *after* cleaning. Soil can make some disinfectants less effective. On colorfast, non-metal surfaces, you can disinfect with a solution of 1/2 to 1 cup household chlorine bleach per gallon of water. Do not use in the air conditioning system. Milder, less corrosive disinfectants include alcohols, phenolics, and hydrogen peroxide.

#### 5. Consider Borate Treatment

Having a professional pest control applicator apply a borate treatment to wood framing can provide resistance to termites, decay, and mold. Other fungicides may also help inhibit mold regrowth during drying. Do not apply sealants to wood.

#### 6. Flush the Air

After cleaning and disinfecting, air out the building. Use fans in windows to pull mold spores to the outdoors.

#### 7. Speed Dry

Dry all wet materials as quickly as possible. Close windows and turn on air conditioner or heat, run fans, and use a dehumidifier, if possible. If there is no power, keep windows open.

#### 8. Remain on Mold Alert

Continue looking for signs of moisture or new mold growth. New mold can form in as little as two to three days if materials stay wet. Wood and other materials that may look dry can still be wet enough to support regrowth. If mold returns, repeat cleaning and, if possible, use speed drying equipment and moisture meters. Regrowth may signal that the material was not dry enough or should be removed.

#### 9. Do Not Restore until all Materials Have Dried Completely

Wood moisture content should be less than 20 percent. Do not use vinyl wallpaper, oil-based paint, or other interior finishes that block drying to the inside.



*Mold can spread quickly in buildings that have experienced flooding. It is important to begin the drying out process as soon as possible to prevent further damage.*

*– Photo by Mary Ruffin Hanbury*

## As the Floodwaters Recede— A Checklist of Things To Do

The following checklist will help you respond to flood damage in historic and older buildings. Read the steps through carefully and take time to plan. While it is tempting to wade right in with a shovel and mop, it is very important to develop a plan for cleanup and rehabilitation. Unfortunately, overly zealous cleanup efforts can result in historic materials being carted away, excessively rough cleaning methods, and the unnecessary loss of historic fabric. The best way to prevent additional damage to historic structures and materials during a time of duress is to use caution and plan ahead.

- Follow all emergency rules, laws, and regulations
- Turn off all utilities
- Document building damage
- Wear protective clothing
- Stabilize any unstable structures with temporary bracing
- Use caution when pumping basement water
- Keep building properly ventilated
- Clean everything that got wet with a disinfectant
- Allow saturated materials to dry using natural ventilation
- Check for foundation damage
- Replace soil around foundation
- Save historic materials if possible
- Use caution when removing lead-based paint or any products containing asbestos
- Clean and repair roof and roof drainage systems to protect building from future damage

FEMA Region IX  
1111 Broadway, Suite 1200  
Oakland, CA 94607  
(510) 627-7100  
(AZ, CA, GUAM, HI, NV,  
CNMI, RMI, FSM, American  
Samoa)

FEMA Region X  
130 228th Street, SW  
Bothell, WA 98021  
(425) 487-4600  
(AK, ID, OR, WA)

Assistance of various types is available from your **state historic preservation office**. Assistance includes survey and assessment of damage of historic resources. In addition the SHPO administers the historic rehabilitation tax credit program for owners of income producing properties certified by the SHPO as historic rehabilitation projects. These tax credits may help to offset the costs of carrying out flood damage repair. Other specific flood-related assistance may be available in your states. To find the SHPO in your state call (202) 624-5465 or go to [www.ncshpo.org](http://www.ncshpo.org)

The **National Endowment for the Arts' Museum Program** is concerned primarily with works of art and with institutions that care for and exhibit works of art. Funds from several categories within the Museum Program can be applied toward disaster planning. For more information call (202) 682-5400 or go to [www.arts.gov](http://www.arts.gov).

The **American Institute for the Conservation of Historic and Artistic Works (AIC)** has established a website for sharing and disseminating information on the recovery of cultural materials. AIC's **Disaster Recovery Page** has key links to resources useful for the recovery of collections affected by the hurricane. For more information go to [aic.stanford.edu](http://aic.stanford.edu).

The **Small Business Administration (SBA)** can provide both direct and bank participation disaster loans to qualified homeowners and businesses to repair or replace damaged or destroyed private property when the SBA administrator declares a "disaster loan area" under SBA's statutory authority. For more information go to [www.sba.gov/disaster\\_recovery/index.html](http://www.sba.gov/disaster_recovery/index.html) or call (800) 659-2955.

The **National Center for Preservation Technology and Training (NCPTT)** uses technology to serve the future of America's heritage through applied research and professional training. The Center's website lists useful publications and assessment tools for disaster recovery efforts. For more information go to [www.ncptt.nps.gov](http://www.ncptt.nps.gov).

### About the Authors

This publication is adapted from the State Historical Society of Wisconsin's *Treatment of Flood-Damaged Older and Historic Properties*, prepared by Jim Sewell, senior preservation architect. Richard Wagner of David H. Gleason Associates drafted the illustrations based on Mr. Sewell's original drawings. The section on mold removal was developed by Claudette Hanks Reichel, Ed.D., professor and extension housing specialist at LSU AGCenter, Louisiana State University.



**NATIONAL TRUST**  
for HISTORIC PRESERVATION®

The National Trust for Historic Preservation is a private, nonprofit membership organization dedicated to protecting the irreplaceable. Recipient of the National Humanities Medal, the Trust was founded in 1949 and provides leadership, education, advocacy, and resources to save America's diverse historic places and revitalize communities. Its Washington, DC headquarters staff, six regional offices and 26 historic sites work with the Trust's 270,000 members and thousands of local community groups in all 50 states. For more information, visit the Trust's web site at [www.nationaltrust.org](http://www.nationaltrust.org).

## Offices of the National Trust for Historic Preservation

### Headquarters

1785 Massachusetts Avenue, N.W.  
Washington, D.C. 20036  
(202) 588-6296

### Southern Field Office

1785 Massachusetts Avenue, N.W.  
Washington, D.C. 20036  
(202) 588-6107  
(District of Columbia, Maryland,  
Virginia, West Virginia)

### Midwest Office

53 West Jackson Blvd., Suite 350  
Chicago, IL 60604-2103  
(312) 939-5547  
(Illinois, Indiana, Iowa, Michigan,  
Minnesota, Missouri, Ohio, Wisconsin)

### Northeast Office

Seven Faneuil Hall Marketplace,  
4th Floor  
Boston, MA 02109-1649  
(617) 523-0885  
(Connecticut, Maine, Massachusetts,  
New Hampshire, New York, Rhode  
Island, Vermont)

### Northeast Field Office

6401 Germantown Avenue  
Philadelphia, PA 19144  
(215) 848-8033  
(Delaware, New Jersey, Pennsylvania)

### Southern Office

William Aiken House  
456 King Street  
Charleston, SC 29403-6247  
(843) 722-8552  
(Alabama, Florida, Georgia,  
Kentucky, Louisiana, Mississippi,  
North Carolina, South Carolina,  
Tennessee, Puerto Rico,  
Virgin Islands)

### Mountains/Plains Office

535 16th Street, Suite 750  
Denver, CO 80202-2910  
(303) 623-1504  
(Colorado, Kansas, Montana,  
Nebraska, North Dakota, South  
Dakota, Utah, Wyoming)

### Southwest Office

500 Main Street, Suite 1030  
Fort Worth, TX 76102-3943  
(817) 332-4398  
(Arkansas, New Mexico, Texas,  
Oklahoma)

### Western Office

8 California Street, Suite 400  
San Francisco, CA 94111-4828  
(415) 956-0610  
(Alaska, Arizona, California,  
Hawaii, Idaho, Nevada, Oregon,  
Washington, Pacific island territories)

Preservation Books are published by the National Trust for Historic Preservation. For a complete list of titles call or write: Preservation Books, National Trust for Historic Preservation 1785 Massachusetts Avenue, N.W. Washington, D.C. 20036 (202) 588-6286 FAX (202) 588-6223, or visit our web site at [www.preservationbooks.org](http://www.preservationbooks.org).

Copyright 1993, 2005 National Trust for Historic Preservation

Richard Moe  
President  
National Trust for Historic Preservation

Peter Brink  
Senior Vice President  
Programs

Katherine Adams  
Director  
Center for Preservation Leadership

Elizabeth Byrd Wood  
Editor

Reed Beebe  
Business Manager

National Trust Forum is a membership program for preservationists—from board members to students, from architects to educators, from preservation commissioners to planners, from volunteers to restoration contractors. Forum membership provides you with the knowledge, tools and resources to protect your community. As a Forum member you receive a subscription to *Preservation* magazine, *Forum Journal*, and *Forum News*. Benefits also include discounts on conferences and all publications listed in the Preservation Books catalog as well as participation in financial/insurance assistance programs, technical advice and access to Forum Online, the online system designed for the preservation community. To join send \$115 to: National Trust Forum National Trust for Historic Preservation 1785 Massachusetts Avenue, N.W. Washington, D.C. 20036 (202) 588-6296 [forum.nationaltrust.org](http://forum.nationaltrust.org)

*This document is intended to provide general information. It should not be understood to offer legal, architectural, environmental, engineering or other professional services, or an opinion with regard to a specific property or condition. If legal, architectural, environmental, engineering advice or other expert assistance is required, the services of a qualified professional should be sought.*

*We encourage you to duplicate this material for distribution to anyone who might find it useful. It is our intent to get this information as quickly as possible to those individuals responsible for flood-damaged older and historic buildings.*